

Status of the transfer beam lines for the DESIR facility

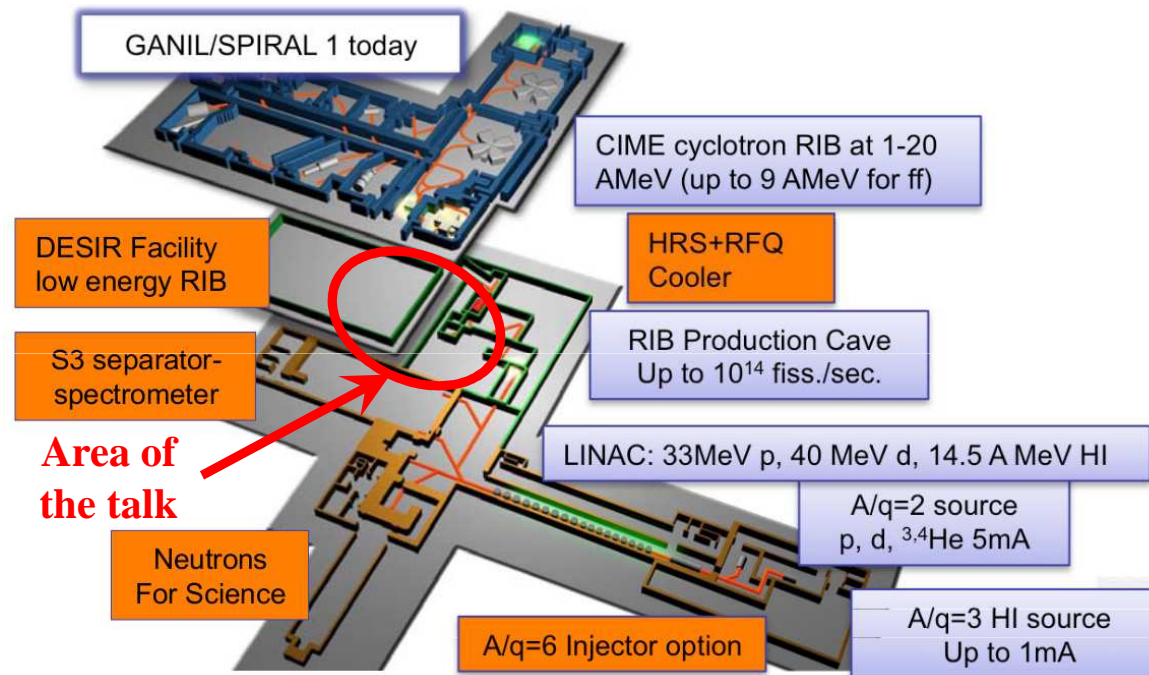

The beam dynamic point of view

L. Perrot : perrot@ipno.in2p3.fr , CNRS-IN2P3-IPNO

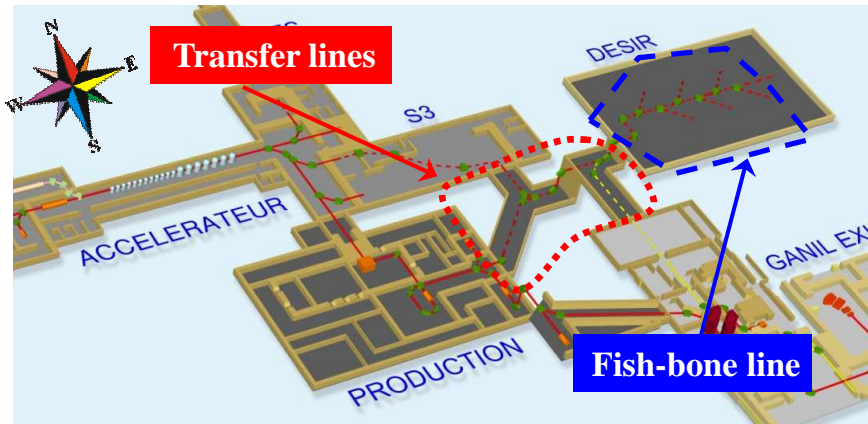

Nuclides going to DESIR will come from 3 different places :

- **S2** - The RIB production module + SHIRAC + HRS ensemble
- **S3** - The S3 Low Energy Branch (gas catcher + HRS)
- **S1** - SPIRAL1 through the LIRAT line

- 3 Interconnected beam lines (S1+S2+S3): underground and outside DESIR
- 1 Fish bone inside DESIR building

Total length ~140m

Working range:

- Transverse emittance : up to $20 \pi \cdot \text{mm} \cdot \text{mrad}$ (RMS)
- Beam energy : $10 \text{keV} < E_b < 60 \text{keV}$
- 1+ beam

Quadrupoles (focalization), deflectors and steerers (orbit correction) will be electrostatic

- All lines calculated using GALOPR and TRANSPORT codes
- Contribution to the optical design to VINCA institute of Belgrade (using GICOSY)
- TraceWin can provide systematics optimizations (steerers and diagnostics implantations)

Nominal Input beam : $\text{Env}_{x,y} = 6 \text{mm}$, $\epsilon_{x,y \text{ RMS}} = 80 \pi \cdot \text{mm} \cdot \text{mrad}$, $\Delta E/E = 0.004 \text{pm}$, $E = 60 \text{kV}$, $M = 122$

S3 – transfer line
 from S3 (-8.5m) up to DESIR (+1.5m)

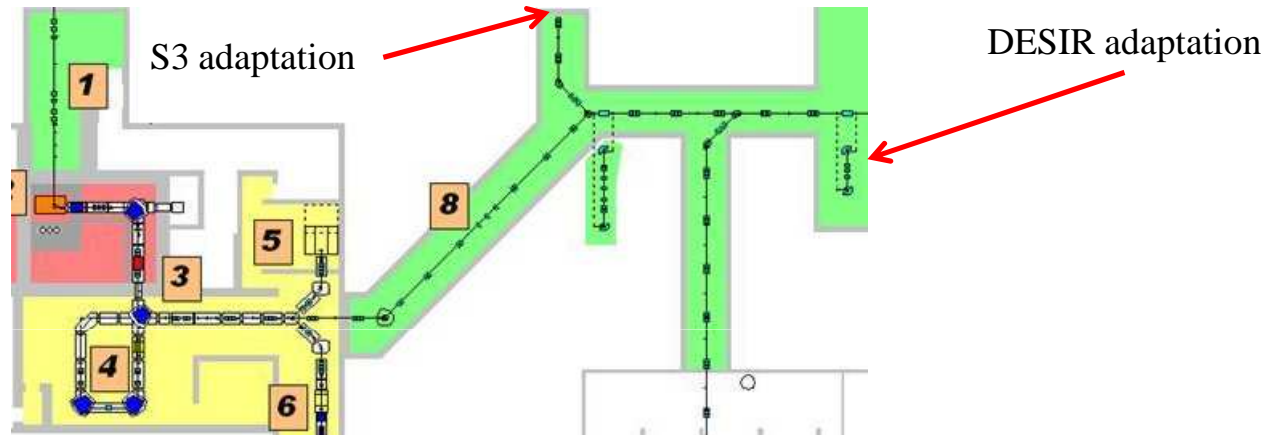

Length = 43.64m

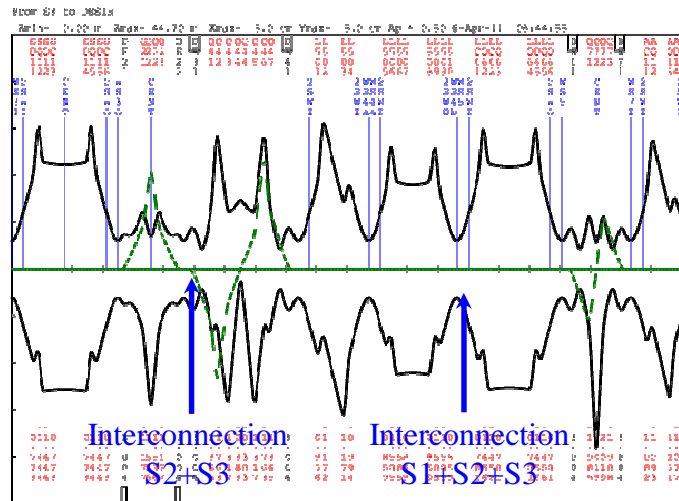

S1 – transfer line
From LIRAT (-1.75m) up to DESIR (+1.5m)

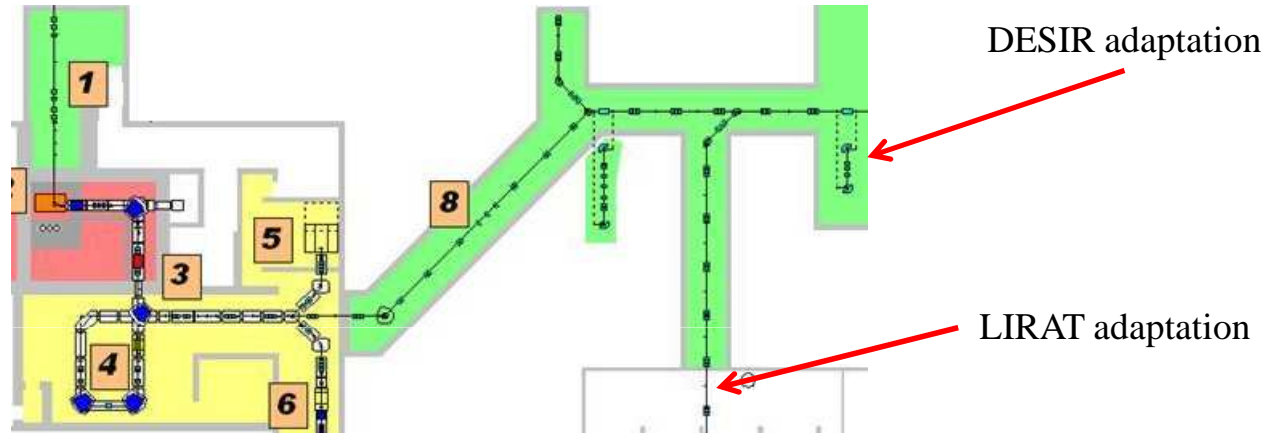

Length = 35.69m

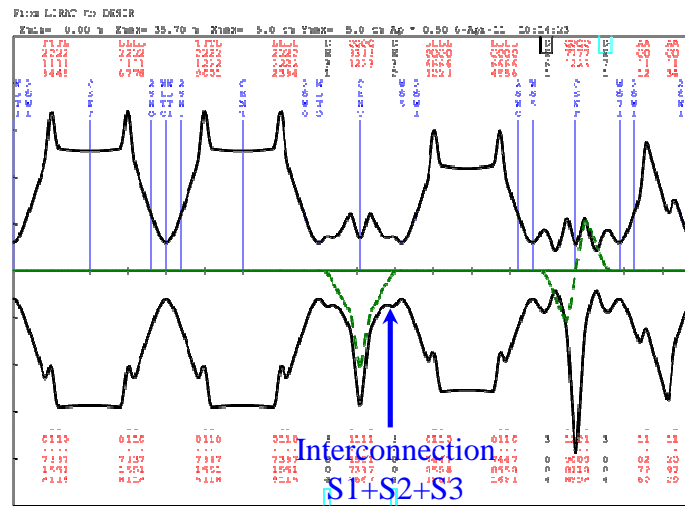

Transport code calculation

S2 – transfer line

From RIB Production building (-8.5m) up to DESIR (+1.5m)

From matching point in
Prod. Building

to matching point
in DESIR fish bone

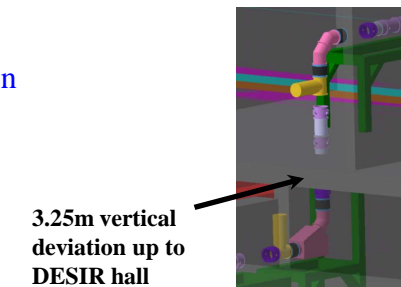
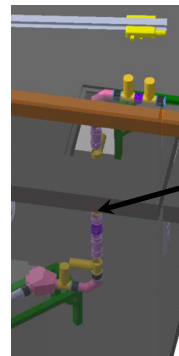
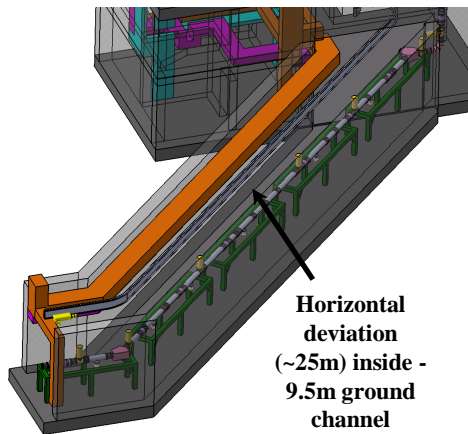
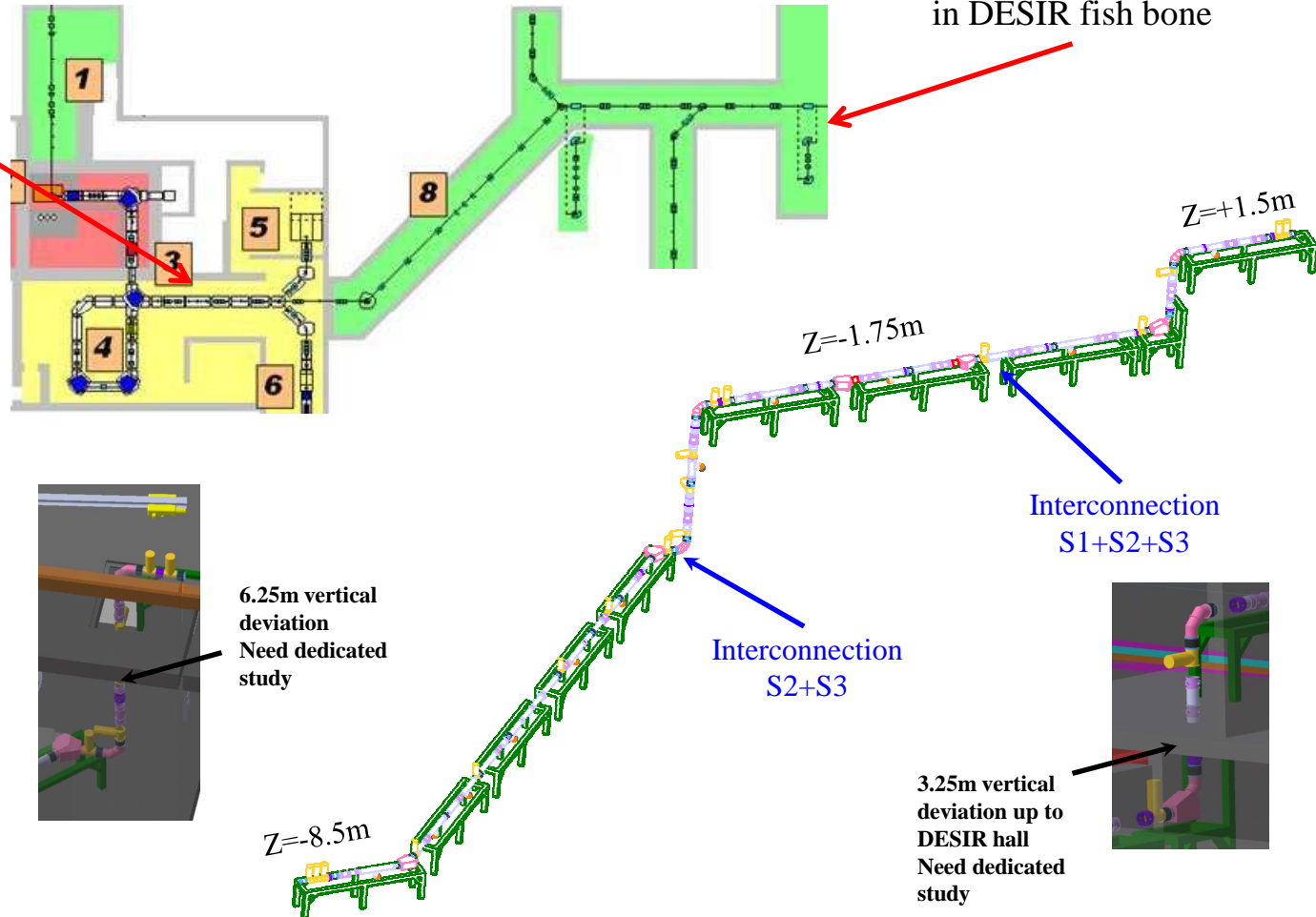

Optic of the transfer beam line from SPIRAL2 production up to DESIR Hall

$^{122}\text{Sn}^{1+}$ beam at 60keV, 2 RMS envelops + dispersions

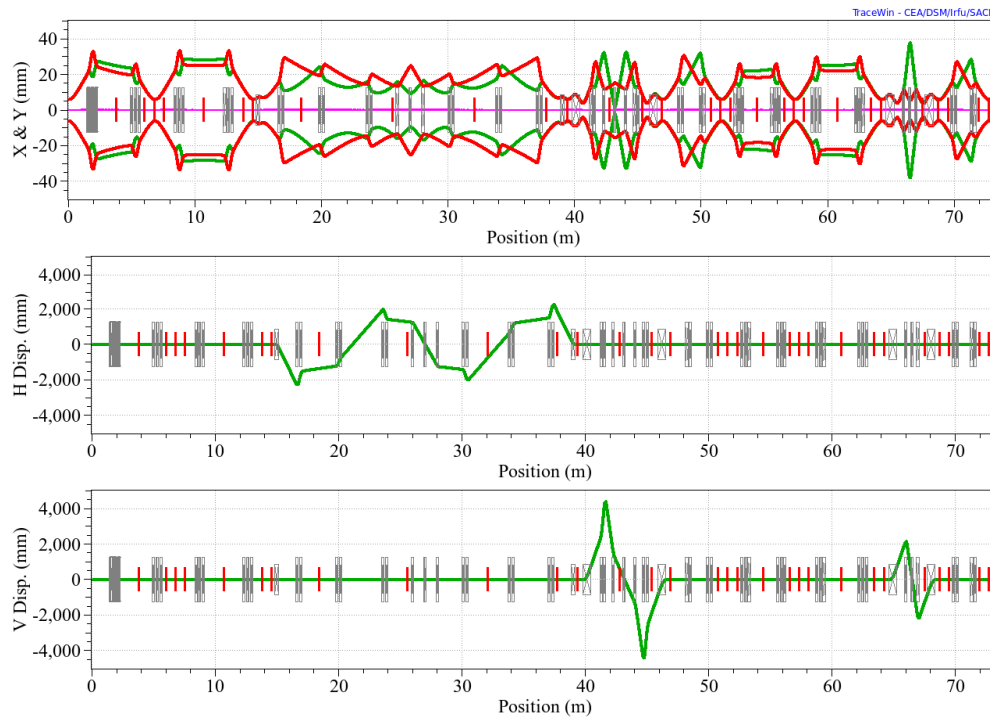

- Length : 74m
- 9 sub-sections
- 1 horizontal déviation ($\Delta x = 17\text{m}$)
- 2 vertical deviations ($\Delta z = 6.25$ and 3.25m)

- Horizontal and vertical achromat are fulfill
- Envelops stabilities and sizes lower than $\pm 40\text{mm}$ at 2RMS.
- Deflector potential up to $E = 3\text{kV/cm}$
- Quadrupoles voltages $< 4\text{kV}$

Optic of the transfer beam line from SPIRAL2 production up to DESIR Hall

Errors calculations :

- Contribution of spreads and deviations (beam and elements) need to error studies.
- Beam stability along lines and corrections give us the optimum implantations of the elements (quadrupoles & steerers)
- The results show that small improvements must be done in particular for steerers and diagnostics implantations

Input Beam	
Displacement $\delta x, \delta y$ (mm)	± 0.25
Displacement $\delta x', \delta y'$ (mrad)	± 0.25
Longitudinal displacement $\delta\phi$ ($^\circ$) δE (eV)	$\pm 0.002^\circ, \pm 6\text{eV}$
Transverse emittance growth (%)	± 1
Longitudinal emittance growth (%)	± 0.1
Transverse mismatch (%)	± 1
Longitudinal mismatch (%)	± 0.1
Current (nA)	± 1

Elements (Quads)	
Field gradient (%)	± 1
Shift (mm)	± 0.1
Rotation over X and Y ($^\circ$)	± 0.05 ($< \pm 0.9\text{mrad}$)
Rotation over Z ($^\circ$)	± 0.15 ($< \pm 2.6\text{mrad}$)

Diagnostic	
Size precision (mm)	± 0.5
Waist precision (mm)	± 0.5
Position precision (mm)	± 0.5

Contributions of the input beam and quadrupoles precision according diagnostics accuracy can be study separately or mixed.

1. Impact of the input beam errors on beam alignment : done
2. Impact of input beam errors & quadrupoles accuracy on beam matching and alignment : done

Optic of the transfer beam line from SPIRAL2 production up to DESIR Hall

1. Impact of the input beam errors on beam alignment

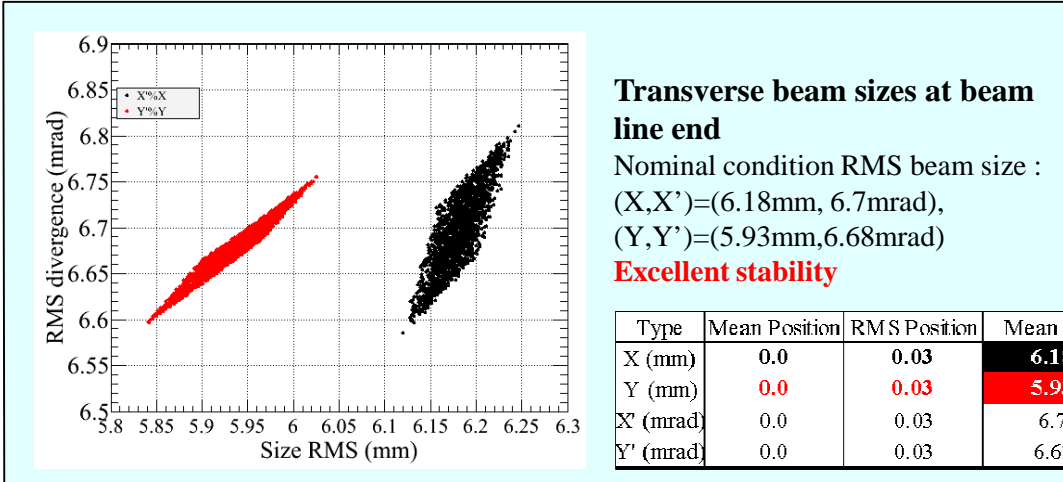
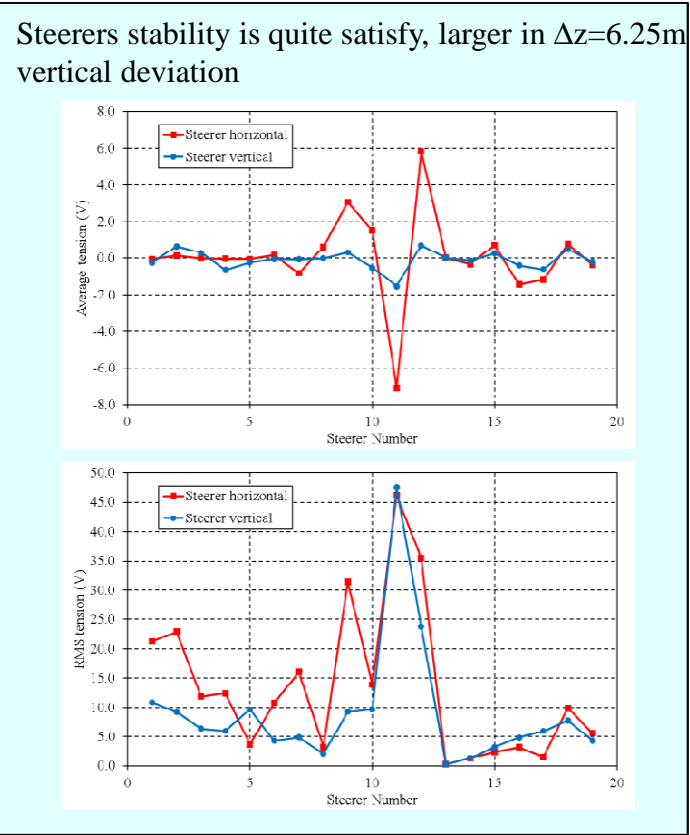
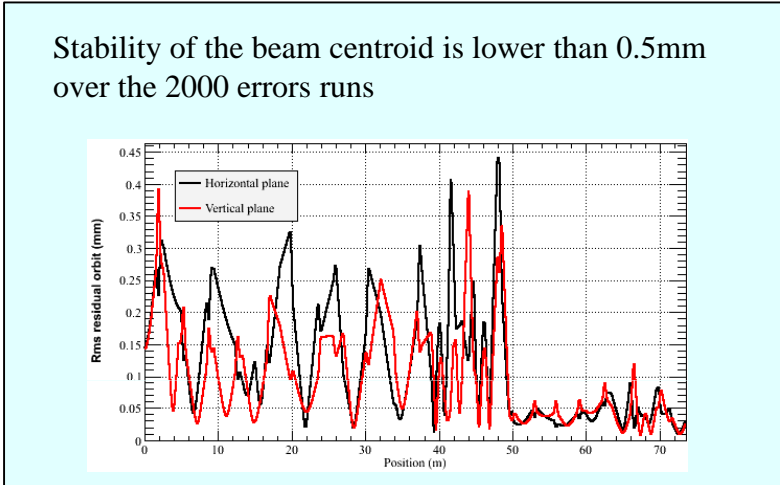

Optic of the transfer beam line from SPIRAL2 production up to DESIR Hall

2. Impact of input beam errors & quadrupoles accuracy on beam matching and alignment

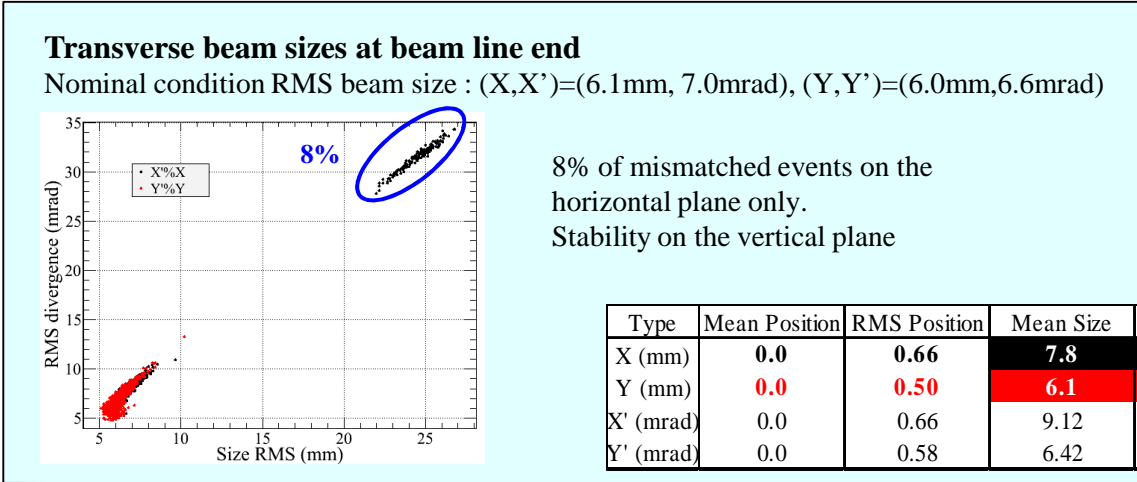
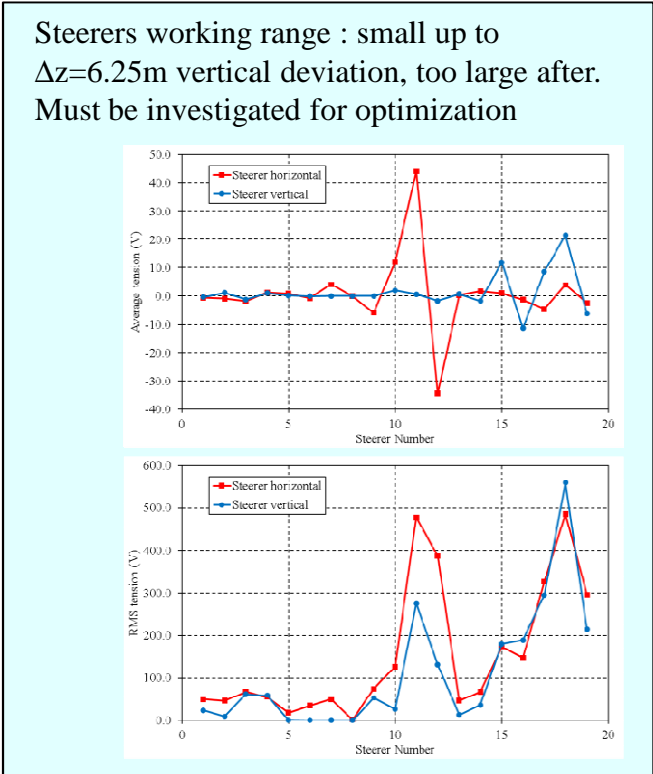
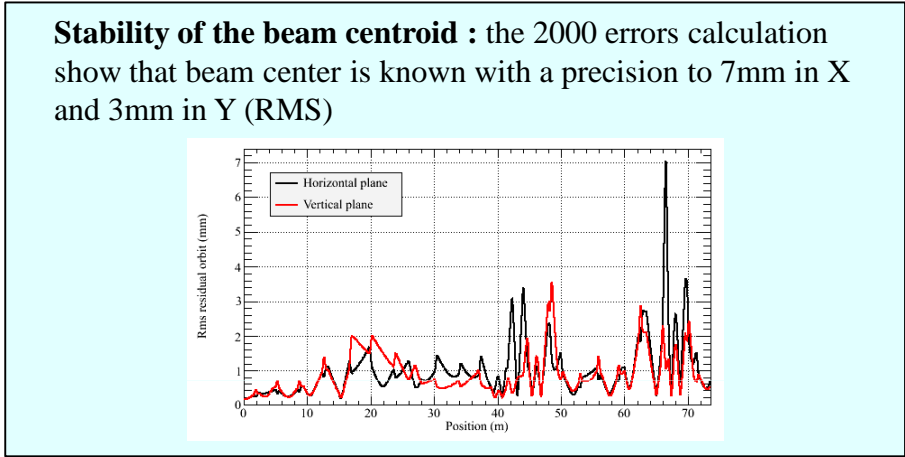

Summary

- General lines design have been done (using 3 different codes, excellent agreement),
- Building is fitting with the process
- Details implantation including steerers
- Orbit correctors locations optimization
- Diagnostics locations optimization is almost done

It is time to make a new mechanical integration in order to validate the quad+deflector+steerer+diag implantation

- Follow the work on others beam transfer line (optimization, errors calculation, mechanical integration)
- Start the real design of the lines in the DESIR Hall according the various requirements and constraints
- Lines vacuum design

Fine

Beam lines task up to the DESIR facility : consists of designing various electrostatic steerers, focusing lenses, electrostatic benders and beam diagnostic components such as faraday cups and measuring devices as well as slits and pumping stations.

Current discussion can be summarize in 5 phases with the laboratories involved given in parentheses:

1. **Design of the beam lines:** beam dynamics studies, beam diagnostics definition, command-control (EPICS), safety and vacuum evaluation, and mechanical integration. (IPN Orsay, CENBG Bordeaux, CSNSM Orsay, GANIL, BARC)
2. **Construction and test of a prototype section** to validate the conceptual design (IPN Orsay, CENBG Bordeaux, GANIL, BARC)
3. **Fabrication** of the final components of the beam-lines (BARC, IPN Orsay, CENBG Bordeaux)
4. **Installation** at GANIL (GANIL, BARC, IPN Orsay, CENBG Bordeaux)
5. **Commissioning** (without and with beam) of the beam lines (GANIL, CENBG Bordeaux, BARC)

IPN Orsay will lead the tasks 1 and 2 :

- Beam lines design (in 2011: beam optics + mechanics)
- Prototype section realization

March 2010 : agreement signed for the creation of an Associated International Laboratory (LIA) between France (CNRS, CEA, GANIL) and India (BARC + TIFR) in the SPIRAL2 context

October 2010 : First joint French-Indian meeting at GANIL

New opportunities of collaboration !

Exchange and discussion between DESIR collab. and BARC (Bhabha Atomic Research Centre)

BARC propose to contribute to (delivery end 2013) :

Beam line design, manufacturing and testing

For the manufacturing :

Electrostatic quad.+steerers, 45°/90° benders,
Switchyards, mechanical structure

DESIR will provide :

Beam diagnostics, slits, faraday cups

Pumping system

Power supplies

Mechanical drawings and details will be done in collaboration

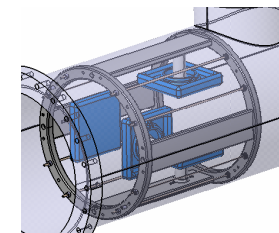
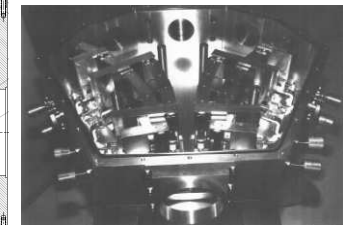
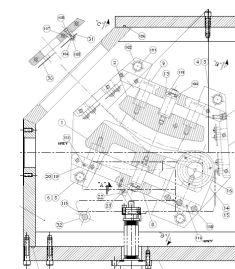

For 140m of beam lines :

- Total cost evaluation : ~3822 k€
- BARC investments cost contribution : 826 k €

Proposed schedule for the design, manufacturing, installation and commissioning of the DESIR beam lines
Phase 2 & 3 are strongly dependant to the financing

DESIR beam lines		2011		2012		2013		2014		2015	
Phase	Key-Word	1st half year	2nd half year	1st half year	2nd half year	1st half year	2nd half year	1st half year	2nd half year	1st half year	2nd half year
1	Design : optics, diag, CC, Safety, Vacuum, mechanics	█		█							
2	Prototype section + Validation			█		█					
3	Manufacturing					█		█			
4	GANIL Installation							█		█	
5	Commissioning : (without/with beam)									█	